

IoT-Based Vaname Shrimp Pond Water Quality Monitoring Using the Quamonitor Tool

Marwana¹, Rosliana Eso², Husein³

^{1,2,3} Department of Physics Education, Faculty of Teacher Training and Education, Halu Oleo University, Kendari; email: marwanatkj@gmail.com

[Received: 28 February 2024, Revised: 17 May 2024, Received : 27 May 2024]
Corresponding Author: Marwana

ABSTRACT — Pond water pollution is the main problem in vanamei shrimp cultivation, so to overcome this problem, The decline in water quality is caused by a decline in the quality of pH, salinity and temperature in pond water. Researchers created the Quamonitor tool to monitor IoT-based vaname shrimp pond water. The research was conducted using the Research and Development (R&D) method with the Analyze, Design, Develop, Implement and Evaluate (ADDIE) model, assisted by WiFi, MQTT and Node Red networks to monitor water in order to display monitoring results on Android. This study aims to monitor the condition of vaname shrimp pond water quality in the form of pH, temperature, and salinity parameters using pH E-4052C sensor, DS18B20 temperature sensor, TDS/Conductivity DFRobot V1.0 sensor and NodeMCU ESP32 as a data manager and system controller that runs in real time. The test results of PH sensors, temperature sensors and TDS/conductivity sensors obtained a sensor error percentage of 0.29% for pH parameters, 1.7% for temperature parameters and 0.41% for salinity parameters. Based on the sensor error value, Thingspeak graph display, real time monitor display on Android, it can be said that the manufacture of the Quamonitor tool for IoT-based vaname shrimp pond water quality monitoring is successful and can function well.

KEYWORDS — IoT; Quamonitor Tool; Sensors; NodeMCU ESP32; Vaname Shrimp

I. INTRODUCTION

Shrimp pond management is one of the leading exports in Indonesia, whose quality needs to be improved [1]. To produce quality shrimp, there must be facilities, namely water as a place for cultivation, the method used is traditional cultivation, because one of the conditions for carrying out cultivation is the presence of cultivated organisms, living media and the place [2]. The water medium used can be river water or sea water, water quality management is an indicator to see water quality through measuring PH, salinity, temperature and brightness [3]. Aquaculture management requires a control system to support the survival of shrimp [4].

This is based on the results of research conducted by [5] which states that shrimp cultivation is influenced by the water quality in ponds, the results obtained by water quality can be monitored via a website-based application. One type of shrimp that is easy to cultivate is the vaname shrimp or commonly called *litopenaeus vannamei*, which is a mainstay commodity in the fisheries sector [6]. To produce superior vaname shrimp requires attention to both internal aspects, such as water quality, as well as internal factors, the quality of water, feed and waters as well as the technology used, good water quality, a temperature of 28-30 °C, water pH of 7-8, 5, and water salinity of 10-30 ppt, because vaname shrimp will develop and grow in these factors and will not die easily [7]. The use of technology in cultivation will help people save time and energy, because the method used is IoT-based, where devices can detect water quality in the form of temperature, salinity and PH [8]. The use and application of IoT technology in the aquaculture sector is highly recommended in assisting the implementation of pond cultivation [9] [10].

Water quality data collection to measure pond productivity. One of them is chemical and physical factors including pH, salinity, water temperature. Based on DKP data from South Konawe district in 2016, the pond land had less than optimal quality, including a water temperature of 33°C which was considered high and 27 °C which was low. Apart from that, there are a lot of organic weathering residues so the average pH value is 6. Salinity 30 ppt.

It is important to constantly monitor water quality parameters and take corrective steps when necessary. By monitoring pond water parameters at all times, you can prevent a decrease in the water quality of vaname shrimp ponds and reduce the risk of disease and shrimp death, so a remote monitoring system based on the Internet of Things is needed to make things easier for the farming community and provide contributions and facilities in vaname shrimp cultivation so that accurate data is obtained at any time (*real time*) which is stored automatically in the system. This data can provide information about the water quality in the pond.

Research conducted by [10] designed a pH monitoring system for shrimp pond water that can provide SMS (*Short Message Service*) warnings and also display on the LCD. The overall system test results show that the system can send SMS messages at any change in water quality conditions.

Another research conducted by [11] designed a prototype of a salinity control device in shrimp ponds using a salinity sensor/TDS, with Arduino as data management. The test results of the tool provide information regarding salinity conditions on the 16x2 LCD screen and the availability of each pump for fresh water and sea water as a reaction so that the pond water quality is always in a normal condition. From existing research, there has been a lot of research regarding monitoring pond water quality using pH sensors [13], temperature sensors and TDS sensors [14] [15]. However, this research has not used and utilized the ESP 32 Dev Kit as a processing medium. Apart from that, both studies need development. This is because *Gate Away SMS-based notifications* result in the waste of cellular credit when sending continuous warnings. For this reason, monitoring development is needed, one of which is IoT-based using a WiFi module so that water quality monitoring can be seen in *real time* [16] [17].

One of the microcontrollers that is often used is the ESP 32 dev kit module which is a combination of WIFI and Bluetooth modules. It has been widely used in *internet of things applications* as a control that can use the MQTT protocol or a *web server* as

a link between sensors and communication devices in the form of *cellphones* to send appropriate messages. topics desired by the user.

The Internet of Things (IoT) is a solution to various problems in cultivating vaname shrimp remotely. IoT has a concept where various physical devices (such as sensors, electronic devices, vehicles, household appliances, etc.) are equipped with technology that allows them to communicate with each other and exchange data via the internet network. This concept allows these objects to collect, transfer, and receive data without requiring direct interaction between humans and devices[18] [12] . The main goal of IoT is to create an environment where devices can communicate with each other, collaborate, and work automatically to increase efficiency, convenience, and productivity[20].

Based on this problem, the researcher raised the topic of developing a Quamonitor tool to remotely monitor the water conditions of vaname shrimp ponds based on IoT (*Internet of Things*). This Quamonitor tool can enable users to *real-time* monitoring and collecting data from various devices and environments .

II. METHOD

The steps taken in developing the IoT-based Quamonitor tool are as follows.

A. ANALYSIS

At this stage, researchers analyze the problems behind the emergence of this product development. Preliminary research carried out by researchers took the form of literature studies in several national and international journals.

This stage will be carried out system design which will be able to meet the needs of the system designed by displaying data from the results of tool implementation. Data that has been obtained from the results of sensor testing will then be analyzed from the sensors used. The analysis data obtained is data when the tool is tested and then a comparison will be made with standard tools[21].

B. DESIGN

The research instruments used in this research are as follows.

1. The ESP32 NodeMCU functions as a microcontroller that processes input, output, communication and runs the entire system.
2. The DS18B20 sensor functions to measure water temperature.
3. The E-4052C pH sensor functions to measure the acid-base levels of water.
4. Gravity DFRobot Analog TDS Sensor V1.0 functions to measure water salinity.
5. Jumper cables function to connect electronic components.
6. *The breadboard* functions as a place for a series of electronic components.
7. The function of the charging battery is to change the electrical voltage from the electrical power source into a voltage that suits the needs of the Quamonitor device.
8. LCD (*Liquid Crystal Display*) functions to display images or text.
9. The tool box functions to help protect tools from damage due to dust, dirt or liquid that can enter it. This also helps keep tools clean and ensures that nothing gets lost.
10. The I2C module functions to transfer data between devices connected on a single data bus in an efficient and reliable manner.
11. Pin headers function as connectors like jumper wires or solder-based connectors to create a sturdy and reliable connection between two components or circuit boards.

C. WIRING DESIGN AND HARDWARE SCHEMATICS OF QUAMONITOR TOOLS

Design of water quality monitoring tools for vaname shrimp ponds, pH sensors, temperature sensors and the TDSV1.0 sensor and LCD are connected to the NodeMCU ESP32 wiring and the schematic can be seen in Figure 1.

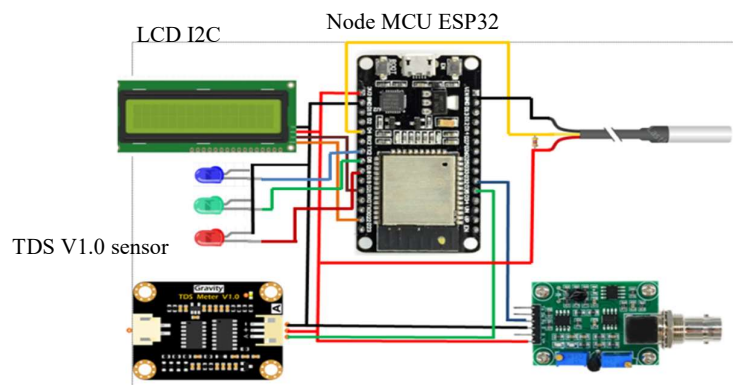

Figure 1. Wiring system hardware

D. SYSTEM BLOCK DIAGRAM

Block diagram can be shown in Figure 2.

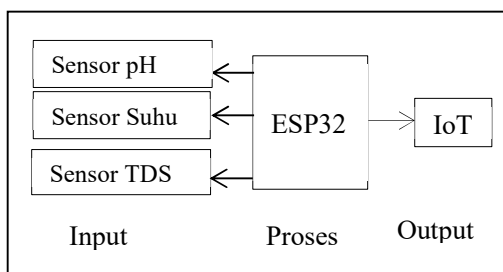

Figure 2. System Block Diagram

Block diagram of the Quamonitor tool works:

1. The E-4052C pH sensor, DS18B20 temperature sensor and TDS V1.0 Gravity sensor function as *input*, where the sensors will send data to the ESP32 NodeMCU
2. Next, the NodeMCU ESP32 as a microcontroller will control or control the input and output of the entire system. When the sensor detects the occurrence electricity usage, the data will be processed according to the program that has been set.
3. The NodeMCU ESP32 output will send data via the MQTT protocol and the data can be displayed on the MyMQTT *Android mobile application*.

E. SOFTWARE DEVELOPMENT DESIGN

The water quality monitoring design is equipped with an E-4052C pH sensor, DS18B20 sensor, and TDS V1.0 Gravity sensor. Water parameters to be measured include pH, temperature and salinity. The flow chart can be seen in Figure 3 .

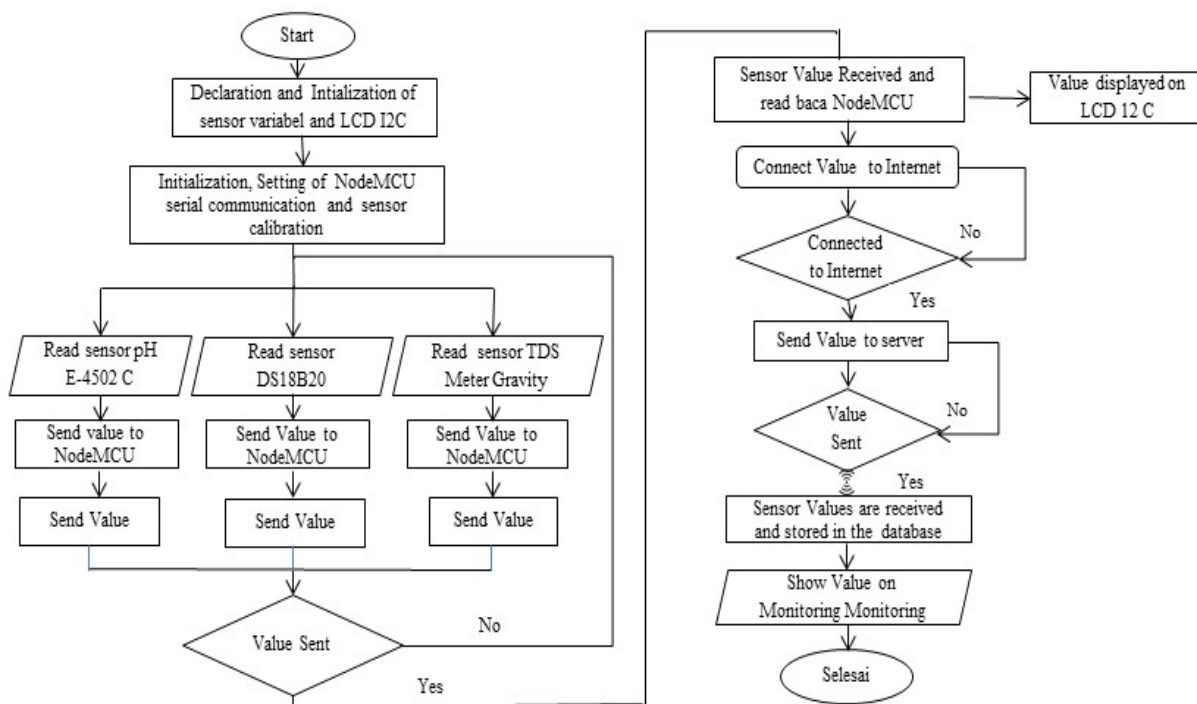

Figure 3. System design flowchart

Information:

1. Starting the initial process.
2. The pH sensor and temperature sensor are analyzed by the sensor serial port.
3. First calibrate the pH sensor and TDS sensor, check the data in the form of maximum voltage and minimum sensor voltage to be entered in the program that has been designed.
4. Input and output installation, initial preparation for installation of input and output devices on the microcontroller.
5. The sensor will read the condition of the water around the container in the form of parameters for acid base levels, temperature and salinity of the water.
6. If the sensor reads the parameters of acid base levels, temperature and salinity, the data will be sent to the NodeMCU ESP32.

7. Next, NodeMCU will manage the data received from the sensors. Before collecting data, NodeMCU will check whether the network is connected or not. After connecting to the network, data will be sent and stored in the MQTT database.
8. Next, data from the MQTT receiver and Node Red will be processed by NodeMCU to display notification data in the MyMQTT application
9. The process of detecting acid base levels, temperature and salinity of water is complete.

F. DEVELOPMENT

The IoT concept developed is a vaname shrimp pond water quality monitoring system using MQTT which supports WAN (connection between countries), Node Red, and My MQTT technology in delivering information to determine the water conditions in vaname shrimp ponds.

G. IMPLEMENTATION

The implementation stage in this research is to unite all components into one unit. This is necessary to ensure that all components work properly. If an error occurs, a review of the system design will be carried out.

H. EVALUATION

The evaluation stage is a process to see whether the system created is successful in accordance with initial expectations or not. The evaluation stage can be carried out in the form of hardware circuit testing, program testing, sensor testing and data analysis in the form of sensor error percentage, MQTT testing.

I. SYSTEM TESTING AND ANALYSIS

Tests have been carried out on the E-4052C pH sensor, DS18B20 sensor and DFRobot Gravity V1.0 TDS sensor using NodeMCU ESP32 as a microcontroller which has an analog value resintivity range of 0 – 4096/12 Bit.

1) E-4052C pH Sensor Testing

Testing the E-4052C pH sensor begins by calibrating the sensor connected to the NodeMCU ESP32 which has an analog output value in the form of sensor voltage in real *time* by inserting the sensor probe into two water samples that have a pH of 4.01 and a pH of 6.68 to find the minimum and maximum voltage, then calculate the calibration value of the voltage and pH type. The calibration values that have been obtained will be entered into the program to convert the analog values to digital values so that the sensor can detect the pH of the water automatically. The sensor voltage for each water solution sample can be seen in Table I.

TABLE I
SENSOR VOLTAGE IN POWDERSBUFFER SOLUTION PH 4.01 AND 6.68

No	Buffer Powder	Analog	Voltage (Volts)
1.	4.01	4071	3.31
2.		4077	3.32
3.		4071	3.31
4.		4075	3.32
5.		7,074	3.31
	Average	-	3.31
6.	6.68	3152	2.56
7.		3193	2.60
8.		3149	2.56
9.		3150	2.56
10.		3149	2.56
	Average	-	2.56

To find the calibration value for the E-4052C pH sensor, the following equation is used.

$$y = \frac{(xA - xB)}{(B - A)}$$

$$y = \frac{(3.31 - 2.56)}{(6.68 - 4.01)}$$

$$y = \frac{0.75}{2.85}$$

$$y = 0.266 \tag{1}$$

Information:

Y = Calibration Value

A = pH 4.01

- B = pH 6.68
- xA = Voltage Value pH 4.01
- xB = Voltage Value pH 6.68

The pH value of the water has been tested using a pH meter, before measuring the pH of the water using the E-4052C pH sensor in vaname shrimp ponds using the internet network and *Android notifications*, the pH meter must be calibrated first. Then data was collected on a good scale from the Quamonitor tool with pH parameters and the pH meter measuring tool so that a comparison of the E-4052C pH sensor value was obtained with the value of the pH meter measuring tool. Testing of the E-4052C pH sensor and pH meter measuring instrument can be seen in Figure 4.



Figure 4. pH and pH Sensor Testing Meters

The table of experimental results from the water pH testing that has been carried out can be seen in Table 2.

TABLE II
 TEST RESULTS FROM WATER PH

Time (s)	pH sensors	PH meter	pH difference	Presentation Error (%)
5	7.43	7.47	0.04	0.53
10	7.47	7.49	0.02	0.26
15	7.46	7.48	0.02	0.27
20	7.48	7.47	0.01	0.13
25	7.47	7.45	0.02	0.27
Average				0.29

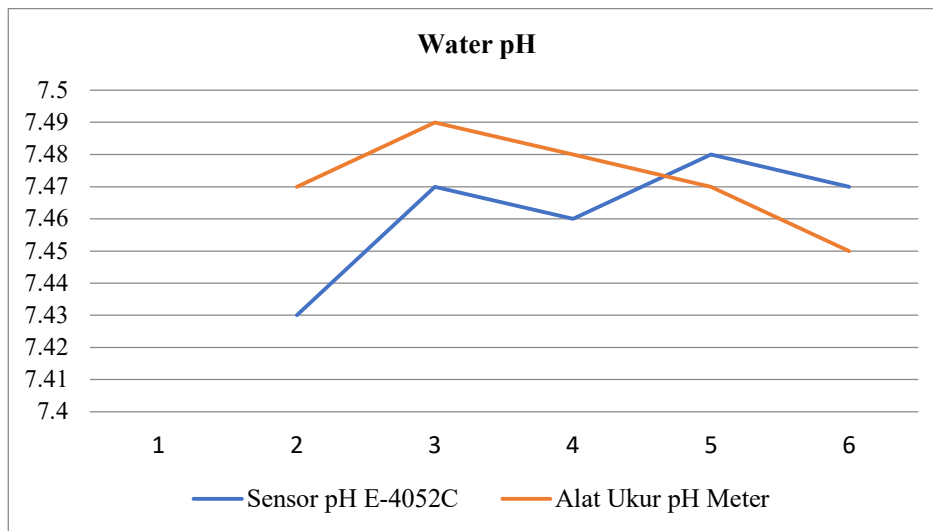

Figure 5. Comparison Chart of pH Sensors and pH Meters

2) DS18B20 Temperature Sensor Testing

Temperature testing is carried out by comparing the values from the Quamonitor tool and the temperature tool, as in Figure 6



Figure 6. DS18B20 temperature sensor testing and DO/Temperature measuring instruments

The results of comparing the Quamonitor and Temperature meter tools can be seen in Table 3.

TABLE III
 WATER TEMPERATURE TEST RESULTS

Time (s)	Temperature Sensor (oC)	Temperature measuring instrument	Water Temperature Difference	Errors (%)
5	26.0	26.6	0.6	2.2
10	26.0	26.3	0.3	1.1
15	26.0	26.5	0.5	1.8
20	27.0	26.8	0.2	0.7
25	28.0	28.8	0.8	2.7
Average				1.7

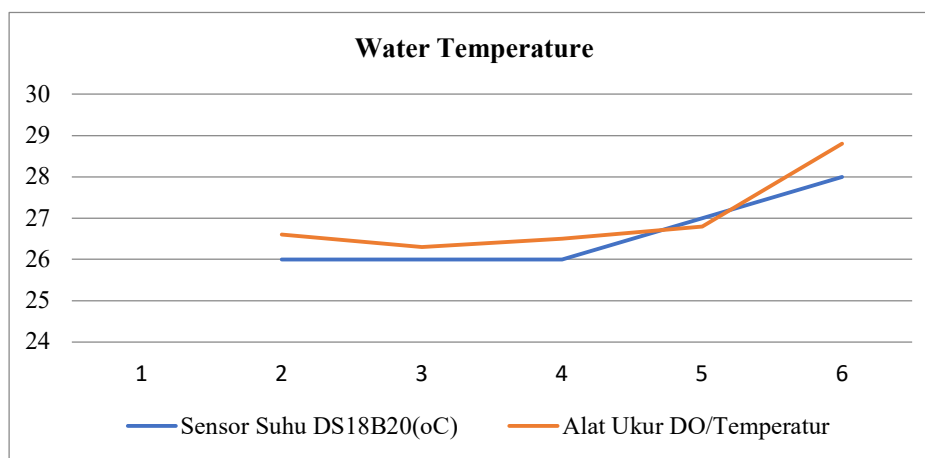

Figure 7. Value Comparison Graph between DS18B20 Sensor and Temperature Measuring Instrument

In Table 3 and Figure 7 is a comparison of test results for water temperature . The difference value is obtained from subtracting the DS18B20 sensor value from the temperature meter value. Here's the formula to find the temperature difference:

$$\text{Temperature difference} = \text{sensor value} - \text{measuring instrument value} \quad (4)$$

error (%) from testing the DS18B20 sensor was calculated . The following is the formula for finding the percentage error in temperature values

$$\text{Persentase error suhu} = \frac{\text{selisih suhu}}{\text{nilai alat ukur}} \times 100\% \quad (5)$$

From the results of testing the DS18B20 sensor, it can be seen in the table that the *error percentage value* obtained was 1.7%. It can be concluded that the water quality monitoring system with temperature parameters using the DS18B20 sensor is said to be successful and functioning well.

3) *DfRobot Gravity V1.0 Conductivity/TDS Sensor Testing*

Before testing is carried out, it is necessary to calibrate the DfRobot conductivity/TDS sensor. This sensor can detect the salinity value in water by determining the maximum salinity and minimum salinity values to determine the sensor ADC value. Then convert the ADC sensor value to digital using the linear equation $Y=ax+b$.

Calculation of the formula for DFRobot conductivity/TDS sensor calibration in Table 4.

TABLE IV
CONDUCTIVITY/TDS SENSOR CALIBRATION DATA DFRobot GRAVITY

Sample no	x	y	x ²	y ²	xy
1	358	0	128164	0	0
2	2773	30	7689529	900	83190
3	2831	34	8014561	1156	96254
Amount	5962	64	15832254	2056	179444

Information:

- x = ADC value read on the sensor
- y = Salinity value contained in Refractometer
- x² = Sensor Squared ADC Value
- y² = Squared salinity value present on the refractometer
- xy = The result of multiplying the ADC value by salinity value read by refractometer

The test results of the conductivity/TDS sensor and refractometer can be seen in Figure 8 and Table 5.



Figure 8. TDS And Conductivity Sensor Testing Refractometer

TABLE V
TEST RESULTS FOR WATER SALINITY

No	Censorship TDS DFRobot (ppt)	Refrato-meter (ppt)	Salinity Difference (ppt)	Error Percentage (%)
1.	29.8	30	0.2	0.67
2.	29.8	30	0.2	0.67
3.	29.98	30	0.02	0.06
4.	29.9	30	0.1	0.33
5.	30.11	30	0.11	0.36
Amount				0.41

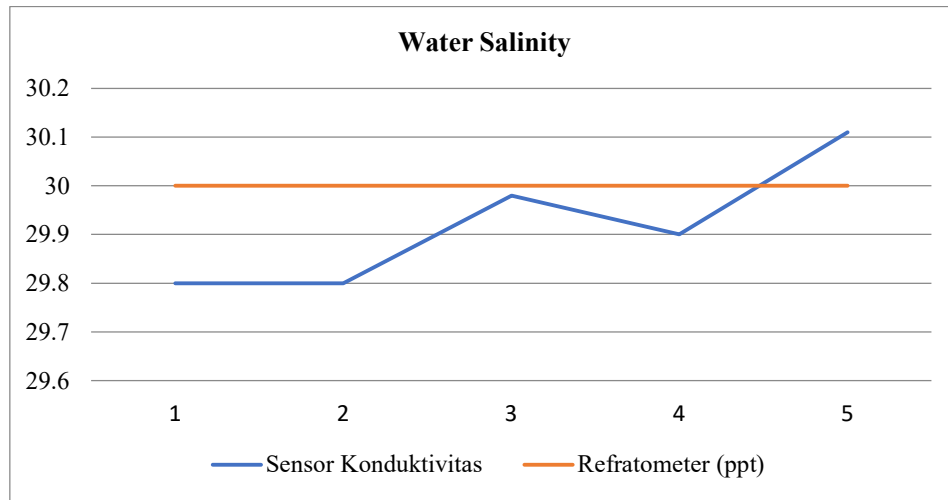

Figure 9. Value Comparison Graph between DFRobots TDS Sensor and Refractometer

In table 5 and figure 9 is a comparison of test results for water temperature . The parameter difference value is obtained by subtracting the salinity value between the DFrobot TDS sensor and the refractometer. The following is the formula for finding the difference in salinity:

$$\text{Salinity difference} = \text{sensor value} - \text{measuring instrument value} \quad (6)$$

the error percentage (%) obtained from the DFrobot TDS sensor test results was determined . The following is the formula for finding the percentage error in temperature values.

$$\text{Persentase error salinitas} = \frac{\text{selisih salinitas}}{\text{nilai alat ukur}} \times 100\% \quad (7)$$

From the test results of the DFrobot Conductivity/TDS sensor, it can be seen in the table that the percentage error value obtained was 0.41 % . It can be concluded that the water quality monitoring system with the Salinity parameter using the DFrobot Conductivity/TDS sensor is said to be successful and functioning well.

The Implementation of hardware in water quality monitoring tools that has been designed to detect acid base levels, temperature and salinity using the E 4502 C pH sensor, DS18B20 temperature sensor and Dfrobot gravity V1.0 and ESP 32 TDS sensors as data managers.

III. RESULTS AND DISCUSSION

The tests carried out include program testing, sensor testing, IoT-based data delivery testing and data testing on servers and notifications to users. The functional testing of the system was carried out in implementing the development of the Quamonitor tool for monitoring water quality which used the E 4502 C pH sensor, DS18B20 temperature sensor and Dfrobot gravity V1.0 and ESP 32 TDS sensors as data managers.

A. NODE RED MONITORING TESTING, MQTT

Testing the MQTT protocol using the publish/subscribe concept and sending graphics can be seen in Figure 10. Figure 10 is monitoring as a form of implementation of the IoT protocol from MQTT. The test is carried out using a container by providing a test water sample where the test material consists of powder with a pH of 4.01 , 6.86 and 9.18, ordinary water and sea water. Test results are shown in Table 6 below

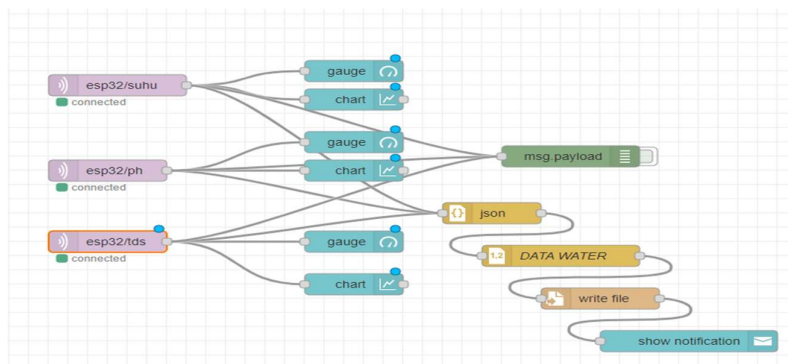

Figure 10. Water Quality Monitoring Display on Node Red

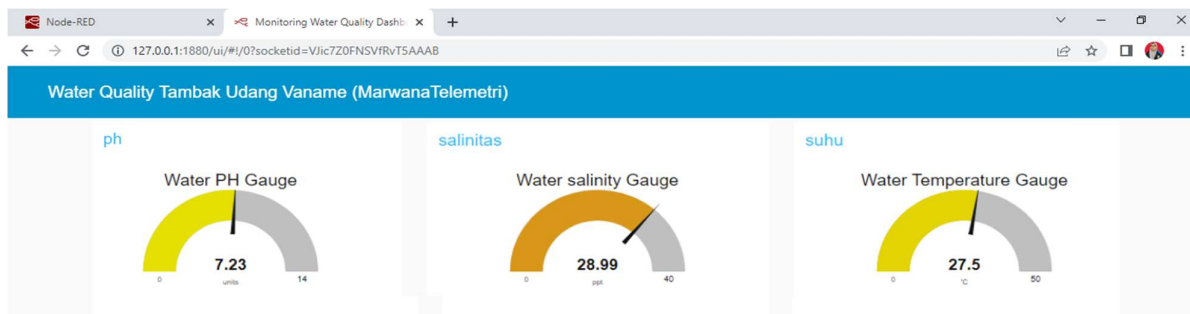

Figure 11. MQTT Dashboard Display Water Quality Monitoring on Node Red

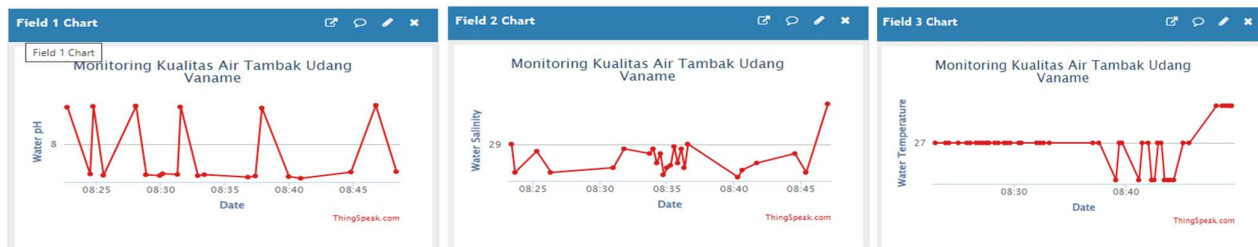

Figure 12. Graphic display of water quality monitoring on Thingspeak



Figure 13. Water Quality Monitoring Display on MyMQTT

TABLE VI
OBSERVATION DATA

No	Date/Time	Water Ph	Water Salinity (ppt)	Water Temperature (°C)
1	2022-09-02/11:01	8.05	19.05	30
2	2022-09-02/11:03	8.07	19.05	30
3	2022-09-02/11:05	7.98	19.07	30.5
4	2022-09-02/11:07	8.34	19.10	30.5
5	2022-09-02/11:09	7.96	19.14	30.5
6	2022-09-02/11:11	8	19.1	31
7	2022-09-02/11:13	7.98	19.09	31
8	2022-09-02/11:15	8.12	19.05	31
9	2022-09-02/11:17	8.14	19.10	31.5
10	2022-09-02/11:19	8.17	19.15	31.5

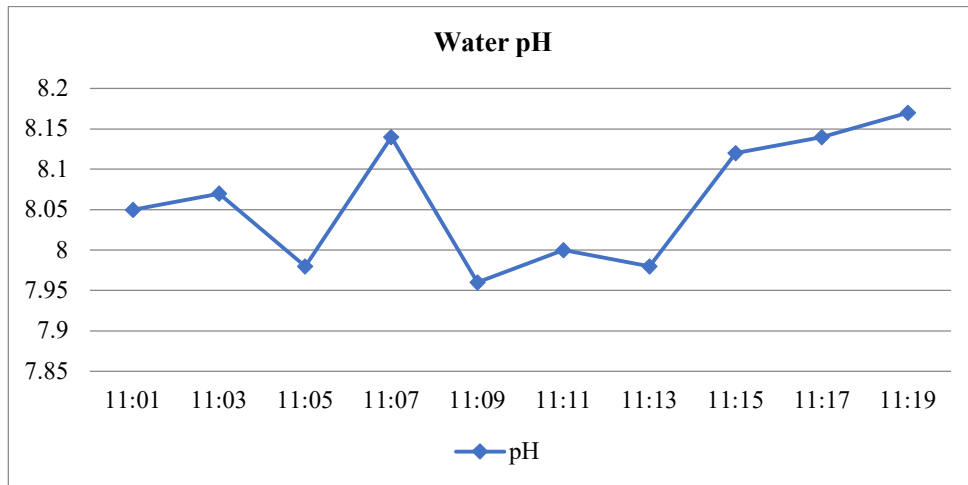

Figure 14. Graph of the Relationship Between Water pH Parameter Values and Time obtained

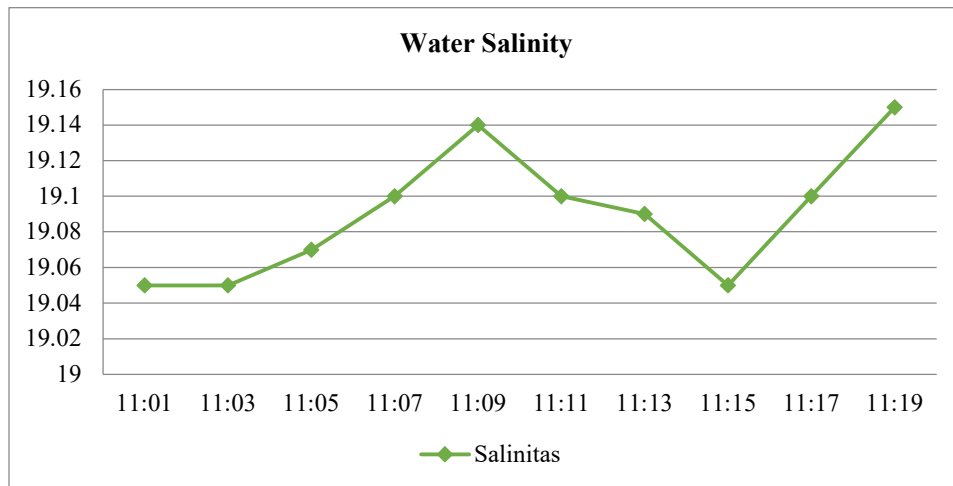

Figure 15. Graph of the Relationship Between Water Salinity Parameter Values and Time Obtained

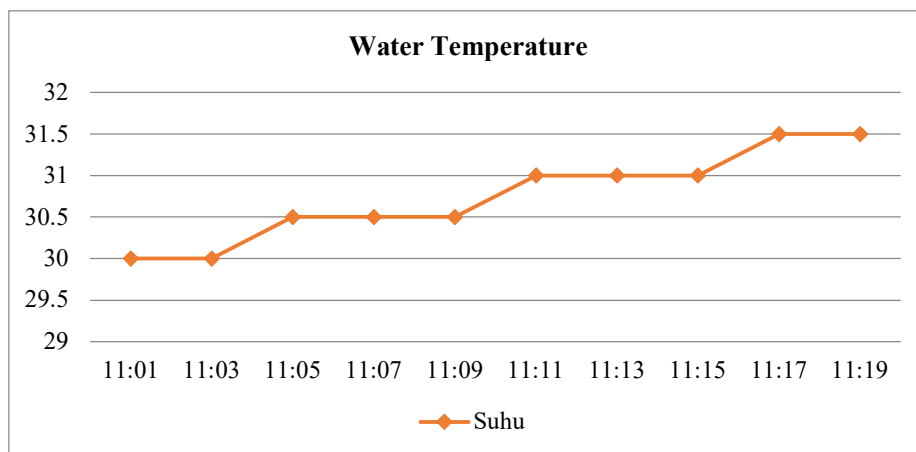

Figure 16. Graph of the Relationship Between Water Temperature Parameter Values and Time Obtained

Based on these tests, it can be seen that the water quality detection system in the form of temperature, pH and water salinity can function well. It can be seen that the sensor can read and measure water quality. The test was carried out on a money container filled with water. The water quality monitoring tool is connected to a power source, namely a lithium battery (charging battery), once connected the tool will operate where the E-4052 C pH sensor will read the pH value of the water, the DFRobot Conductivity/TDS sensor will detect the water salinity value, and the DS18B20 sensor will detect water temperature. Then the

sensor detects the data, the nodeMCU will send the data via the internet to *the database*. The data that has been sent to *the database* will be updated at any time by the broker and will then appear on the main page of the website in the form of numbers and graphs. After that the sensor will work for monitoring.

VI. CONCLUSION

The Quamonitor tool based on *the Internet of Things* (IoT) has been proven to be able to be used to monitor the water quality of white vaname shrimp ponds temperature, pH and salinity of water. Different from other measuring tools, we combine three sensors at once and one microcontroller. Apart from that, this tool also provides a lot of information regarding water quality data in the pond remotely because it is equipped with IoT technology so it can be connected to Android. The test results of the PH sensor, temperature sensor and TDS/salinity sensor obtained a sensor *error percentage* of 0.29 %, 1.7% and 0.41%. From the sensor *error values*, graphs and *real time monitor displays* on Android, it can be said that the creation of an IoT- based vaname shrimp pond water condition monitoring tool was successful and can function well.

It is hoped that further research can be developed by adding a water control system when using an aquarium container.

CONFLICT OF INTEREST

The authors declare no conflict of interest.

REFERENCES

- [1] A. Zamzami, O. Fransisco, I. Irwan, and M. I. Nugraha, "Sistem Monitoring Kualitas Air Tambak Udang Berbasis Internet of Things (IoT)," in *Seminar Nasional Inovasi Teknologi Terapan*, 2021, pp. 1–7.
- [2] S. Anwar and A. Abdurrohman, "Pemanfaatan Teknologi Internet of Things untuk Monitoring Tambak Udang Vaname Berbasis Smartphone Android Menggunakan Nodemcu Wemos D1 Mini," *Infotronik J. Teknol. Inf. dan Elektron.*, vol. 5, no. 2, pp. 77–83, 2020, doi: 10.32897/infotronik.2020.5.2.484.
- [3] M. Marsudiarto, Y. Ariyanto, and S. N. Arief, "Sistem Monitoring dan Controlling Kualitas Air Tambak Udang Vannamei Berbasis Internet of Things (IoT)," in *Seminar Informatika Aplikatif Polinema*, 2020.
- [4] O. Natan, A. I. Gunawan, and B. S. B. Dewantara, "Design and Implementation of Embedded Water Quality Control and Monitoring System for Indoor Shrimp Cultivation," *Emit. Int. J. Eng. Technol.*, vol. 7, no. 1, pp. 129–150, 2019, doi: 10.24003/emitter.v7i1.344.
- [5] D. Eridani, E. D. Widiyanto, and N. Kholid, "Rancang bangun sistem monitoring dan controlling tambak udang windu dengan konsep internet of things menggunakan protokol message queuing telemetry transport," *CESS (Journal Comput. Eng. Syst. Sci.)*, vol. 5, no. 1, pp. 137–145, 2020, doi: 10.24114/cess.v5i1.14718.
- [6] Z. Zainuddin, R. Idris, and A. Azis, "Water Quality Monitoring System for Vannamae Shrimp Cultivation Based on Wireless Sensor Network In Taipa, Mappakasunggu District, Takalar," in *First International Conference on Materials Engineering and Management-Engineering Section (ICMEME 2018)*, Atlantis Press, 2019, pp. 89–92. doi: 10.2991/icmeme-18.2019.20.
- [7] M. M. Faruq and D. Hirawan, "Water Quality Monitoring System In Vaname Shrimp At Tirtayasa District Based On Internet Of Things," *1st Int. Conf. Mater. Eng. Manag. - Eng. Sect.*, vol. 165, 2018.
- [8] F. Meyllianawaty Pratiwy, A. Kinasih Jacinda, and A. Yustiati, "Application of IoT-based Technology in Vaname Shrimp Cultivation: A Systematic Literature," *Asian J. Fish. Aquat. Res.*, vol. 15, no. 6, 2021, doi: 10.9734/AJFAR/2021/v15i630354.
- [9] A. Rifa'i, M. U. H. Al Rasyid, and A. I. Gunawan, "SISTEM PEMANTAUAN DAN KONTROL OTOMATIS KUALITAS AIR BERBASIS INTERNET OF THINGS (IOT) MENGGUNAKAN PLATFORM NODE-RED UNTUK BUDIDAYA UDANG," *JTT (Jurnal Teknol. Ter.)*, vol. 7, no. 1, pp. 19–26, 2021, doi: 10.31884/jtt.v7i1.317.
- [10] N. D. Susanti, D. Sagita, I. F. Apriyanto, C. E. Wahyu, D. A. Darmajana, and A. Rahayuningtyas, "Design and Implementation of Water Quality Monitoring System (Temperature , pH , TDS) in Aquaculture Using IoT at Low Cost," vol. 16, pp. 7–11, 2022.
- [11] A. S. Pratama, A. H. Efendi, D. Burhanudin, and M. Rofiq, "Simkartu (Sistem Monitoring Kualitas Air Tambak Udang) Berbasis Arduino dan SMS Gateway," *J. SITECH Sist. Inf. dan Teknol.*, vol. 2, no. 1, pp. 121–126, 2019, doi: 10.24176/sitech.v2i1.3498.
- [12] H. Hidayat and H. Hambali, "Rancang Bangun Alat Kontrol Salinitas Air Otomatis pada Budidaya Udang Vaname," *Ranah Res. J. Multidiscip. Res. Dev.*, vol. 4, no. 2, pp. 135–143, 2022, doi: 10.31933/rrj.v4i2.457.
- [13] A. B. Pratama, I. Much, I. Subroto, and A. Rihsyah, "Sistem Monitoring Dan Kontrol Kualitas Air Pada Kolam Ikan Koi Berbasis Internet of Things (IoT)," vol. 4, no. 3, pp. 171–180, 2022.
- [14] U. Latipah, Z. Alamsyah, and F. Mamdani, "ANALISIS PERANCANGAN SISTEM MONITORING AIR," no. September, 2022.
- [15] S. T. Elektro, F. Teknik, U. N. Surabaya, S. T. Elektro, F. Teknik, and U. N. Surabaya, "SISTEM MONITORING KUALITAS AIR PADA SISTEM AKUAPONIK BERBASIS IOT Risma Alfia Arif Widodo , Nurhayati , Nur Kholis," 2020.
- [16] F. Febrianti, S. Adi Wibowo, and N. Vendyansyah, "IMPLEMENTASI IoT(Internet Of Things) MONITORING KUALITAS AIR DAN SISTEM ADMINISTRASI PADA PENGELOLA AIR BERSIH SKALA KECIL," *JATI (Jurnal Mhs. Tek. Inform.)*, vol. 5, no. 1, pp. 171–178, 2021, doi: 10.36040/jati.v5i1.3249.
- [17] A. Firdhouzi, P. H. Trisnawan, and D. P. Kartikasari, "Rancang Bangun Sistem Monitoring Kualitas Air dengan menggunakan Arsitektur Jaringan Internet of Things," vol. 4, no. 10, pp. 3623–3629, 2020.
- [18] V. Gnanasagar and V. Mannava, "Design and Implementation of a Controller for a Recirculating Aquaponics System using IoT Design and Implementation of a Controller for a Recirculating Aquaponics System using IoT," no. June, pp. 3–8, 2020.
- [19] S. Mluyati and S. Sadi, "Internet Of Things (IoT) Pada Prototipe Pendeteksi Kebocoran Gas Berbasis MQ-2 Dan SIM800L," *J. Tek.*, vol. 7, no. 2, 2019.
- [20] C. Journal, Y. Thiro, and K. Yunior, "Sistem Monitoring Kualitas Air pada Budidaya Perikanan Berbasis IoT dan Manajemen Data," vol. 6, no. 2, 2019.
- [21] A. Lestari and A. Zafia, "Penerapan Sistem Monitoring Kualitas Air Berbasis Internet Of Things," *LEDGER J. Inform. Inf. Technol.*, vol. 1, no. 1, pp. 17–24, 2022, doi: 10.20895/ledger.v1i1.776.